



STRAMIT®
PURLINS,
GIRTS
& BRIDGING
DETAILING
& INSTALLATION

detailing & installation guide



STRAMIT® PURLINS, GIRTS & BRIDGING DETAILING & INSTALLATION

*Guide to detailing and installation of
Stramit® Purlins, Girts & Bridging
and their accessories.*



IMPORTANT NOTE

The information contained within this brochure is as far as possible accurate at the date of publication, however, before application in a particular situation, Stramit Building Products recommends that you obtain qualified expert advice confirming the suitability of product(s) and information in question for the application proposed. While Stramit accepts its legal obligations, be aware however that to the extent permitted by law, Stramit disclaims all liability (including liability for negligence) for all loss and damage resulting from the use of the information provided in this brochure.

CONTENTS

Selection and Specification

Materials	2
Adverse Conditions	2
Compatibility	2
Specification	2
Structural Adequacy	2

Design Data - *Stramit*[®] Purlin Accessories

Sizes	3
Hole Punching	4
Bridging Hole Location	5
Laps	5
Expansion Joints	6
Detailing of Purlins	6
Fascia Purlins	7

Design Data - *Stramit*[®] Purlin Accessories

Basic Components	8
Bolts	8
Hangers/Services	8
Safety Mesh	8
Typical Purlin Accessory Assemblies	9

Design Data - *Stramit*[®] Bridging

Basic Components	10
<i>Stramit</i> [®] Boltless Bridging	11
<i>Stramit</i> [®] Boltless Bridging Assemblies	12-17
<i>Stramit</i> [®] Bolted Bridging	18
Curved Roofs	19
Detailing Bridging	19
<i>Stramit</i> [®] Large Series Bridging	20

Procurement

Prices	21
Lengths	21
Accessories	21
Orders	21
Lead Times	21
Related Products	21
Delivery/Unloading	21

Installation

Good Practice	22
Inspection	22
Walking	22
<i>Stramit</i> [®] Boltless Bridging	22
Fixing	22
Laps	23
Bolts/Fastening	23
Fly Bracing	23
Welding	23
Roofing Mesh	23

Additional Information

Design Service	23
Further Information	23
Other Products	24
References	24

INTRODUCTION

This Detailing and Installation Guide is complementary to the ***Stramit*[®]** Purlins, Girts & Bridging – Product Technical Manual (incorporating design capacity tables). The Guide contains details on all ***Stramit*[®]** Purlins, Girts, Bridging and relevant accessories. Information is provided to enable detailed purlin design including a wide range of practical component assemblies to cover almost all applications.

Stramit offers a wide range of standard C and Z purlins from 100 to 350 deep in several thicknesses. Downturn lips are also available for both C and Z sections from 150 to 350, including lappable Zs. Special sizes from 100 to 400 are also possible.

Stramit has rationalised the former range of regional proprietary bridging systems. ***Stramit*[®] Boltless Bridging** combines the best features of many of these systems, and has itself been improved to become the superior bridging system.

Customer Support

Stramit has specialist staff in each region to assist with all issues related to purlin detailing and installation. This enables Stramit to provide advice that reflects local conditions and practices.

SELECTION & SPECIFICATION

Materials

Stramit® Purlins and Girts are manufactured from hi-tensile (G450, G500 or G550) galvanised steel, with a minimum Z350 galvanised coating (350g/m²). **Stramit®** Bridging and Purlin accessories are manufactured from steel with a minimum yield of 300 MPa and galvanised coating of Z275 or zinc aluminium alloy AZ150 coating.

Specification

Maintaining the correct specification of purlins, girts and bridging is very important. Even a small change in specification can lead to substantial reduction in performance. Beware of so-called 'equivalent' products that are smaller in size, (and hence capacity) have a lesser coating and even a lower strength grade of steel.

This specification can be found on the Stramit web site and can be easily downloaded on to your documentation.

"All purlins and girts shall be Stramit sections or approved equivalent, supported by submission of section properties, purlin capacity calculations, bridging capacity calculations and a performance warranty, produced and detailed for this project. All sections shall be produced from galvanised steel to AS1397 with a coating mass of at least 350g/m² and designed in accordance with AS4600. All sections should be installed in accordance with the manufacturer's instructions with particular regard to bolt locations and lap sizes".

"Where required for structural or installation purposes, **Stramit® Bridging** shall be installed using pre-made components to manufacturer's instructions. All other accessories shall be supplied by Stramit".

"All structural work shall be completed in a workmanlike manner prior to installation of the cladding material".

Structural Adequacy

It is important that the structural adequacy of each purlin and girt application be established by a practising structural engineer. Limit-state design capacities can be found in the **Stramit®** Purlins, Girts & Bridging – Product Technical Manual.

Adverse Conditions

Stramit® Purlins and Girts will give excellent durability in most applications. In exposed conditions unwashed areas subject to salt-laden air or other corrosive matter may need additional protection. **Stramit® Purlins and Girts** are not recommended for use within 450mm of moist soil.

Compatibility

Contact between galvanised steel and copper (eg. pipework) must be avoided as premature corrosion will occur.

DESIGN DATA

Stramit® Purlins & Girts

Sizes

The table below lists the sizes and thicknesses readily available for purlins and girts.

Shapes other than standard C Section and standard Z Section may be subject to minimum order requirement.

For sections outside this range please contact your local Stramit office.

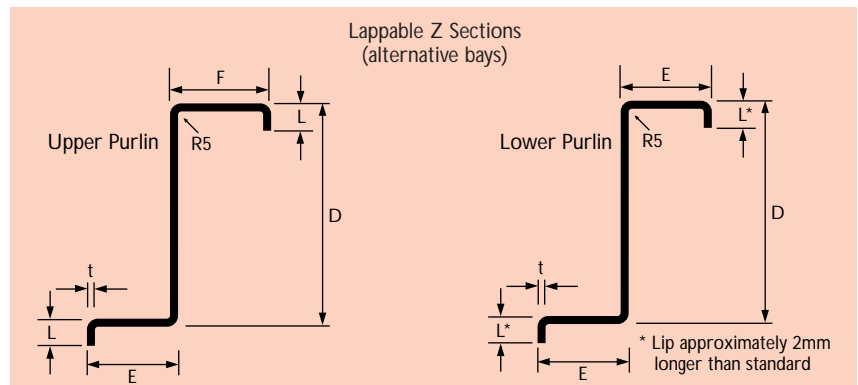
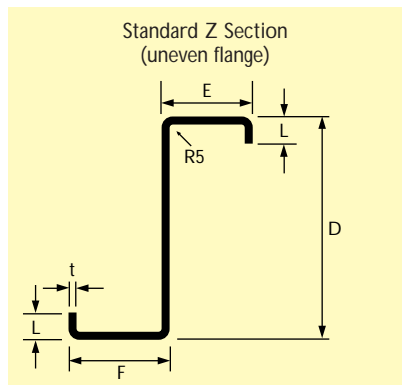
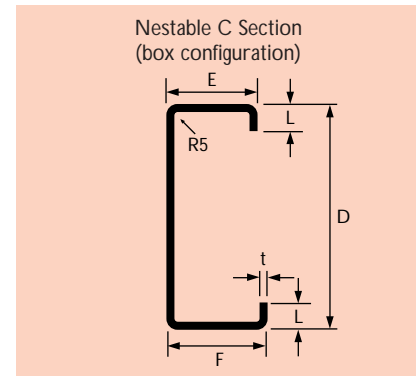
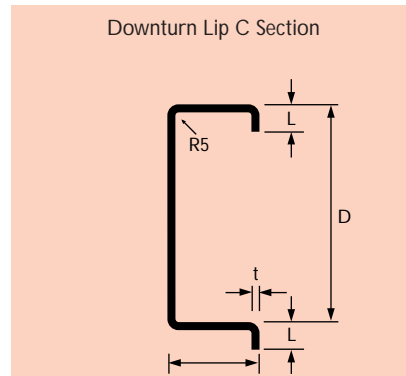
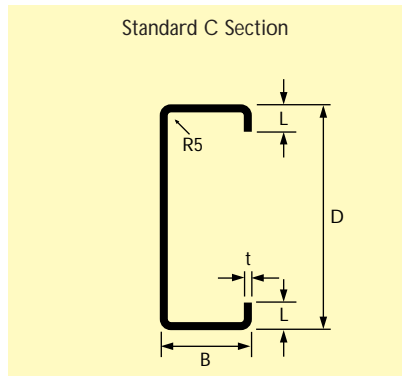

STRAMIT® PURLINS AND GIRTS – C & Z SECTION SIZE & MASS RANGE

Section	Web D mm	Flange B mm	Flange E mm	Flange F mm	Lip L mm	Thickness t mm	Mass kg/m
C/Z100-10	102	51	49	53	12.5	1.0	1.77
C/Z100-12	102	51	49	53	13.0	1.2	2.11
C/Z100-15	102	51	49	53	14.0	1.5	2.61
C/Z100-19	102	51	49	53	15.0	1.9	3.29
C/Z150-10	152	64	61	65	14.5	1.0	2.43
C/Z150-12	152	64	61	65	15.0	1.2	2.90
C/Z150-15	152	64	61	65	16.0	1.5	3.59
C/Z150-19	152	64	61	65	17.0	1.9	4.51
C/Z150-24	152	64	61	66	18.5	2.4	5.67
C/Z200-15	203	76	74	79	16.0	1.5	4.50
C/Z200-19	203	76	74	79	19.5	1.9	5.74
C/Z200-24	203	76	74	79	21.0	2.4	7.21
C/Z250-19	254	76	74	79	19.0	1.9	6.5
C/Z250-24	254	76	74	79	20.5	2.4	8.17
C/Z300-24	300	96	93	100	28.0	2.4	10.18
C/Z300-30	300	96	93	100	31.5	3.0	12.69
C/Z350-30	350	125	121	129	30.0	3.0	15.19

Hole Punching

Stramit® Purlins and Girts are usually delivered with holes punched to details supplied. This allows purlins to be used on arrival at site.

The computer controlled production line allows holes at almost any position or frequency on the web and the flanges. Holes are positioned from hole detail sheets supplied prior to manufacture.

The preferred method of dimensioning is hole centre to hole centre rather than referenced from one end. An overall purlin length is also desirable to provide a data entry dimension check.

Stramit normally supply purlins and girts punched to conventional AISC hole centres. Ensure hole detail sheets show correct hole centres and spacing required and location and type of bridging holes.

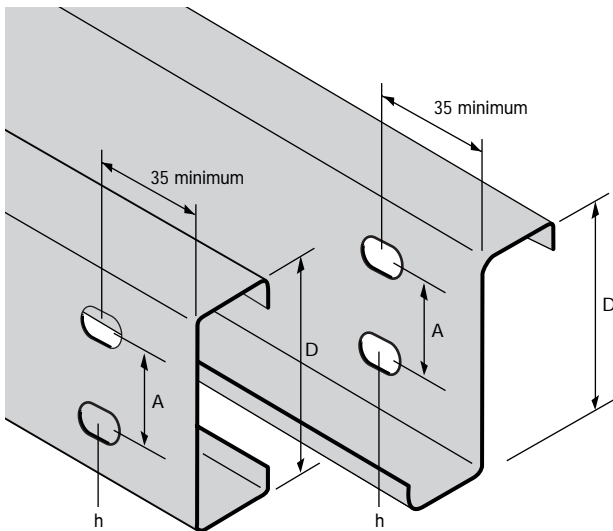

PURLIN SIZE		AISC CENTRES
D	A	h
mm	mm	mm
100	40	18 x 22
150	60*	18 x 22
200	110	18 x 22
250	160	18 x 22
300	210	22 diameter
350	260	22 diameter

*Standard centres in Victoria - 70mm. All accessories supplied in Victoria conform to the 70mm spacing for 150 sections.

Alternative hole sizes, shapes and centres are possible, subject to enquiry.

Bridging Hole Location

Stramit recommends that bridging be installed such that the maximum unbraced length is $20 \times D$ (where D is the purlin web height), or 4000mm whichever is the least. In addition to enhancing purlin performance this requirement assists with the erection of roof sheeting. Location of bridging must be as shown below (to the nearest 50mm), or as determined by the design engineer by computation.

Single or Internal Spans

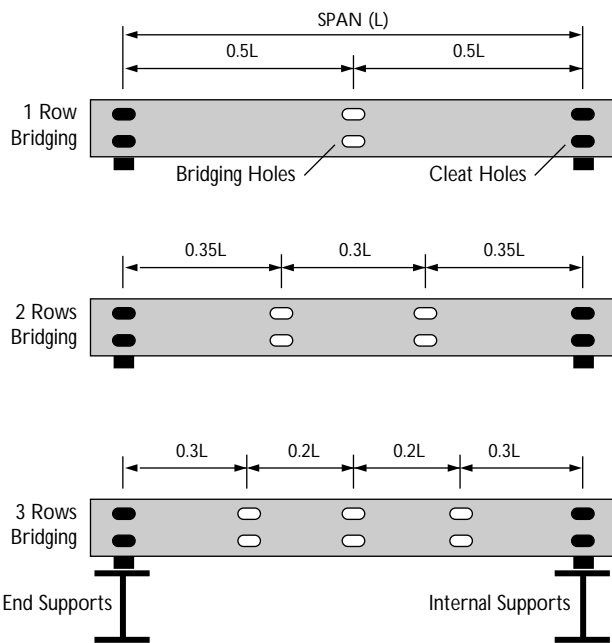

Double or End Spans

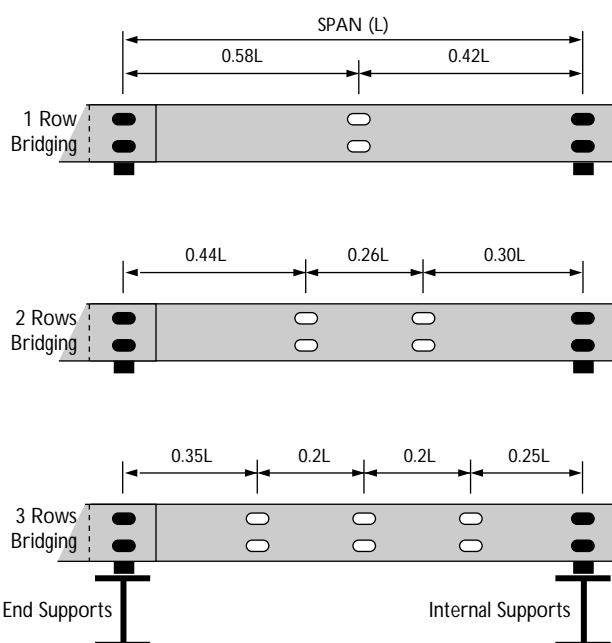

Laps

All lapped Z section configurations generally require a total lap length (bolt centre to bolt centre) of 15% of the span (to the nearest 50mm).

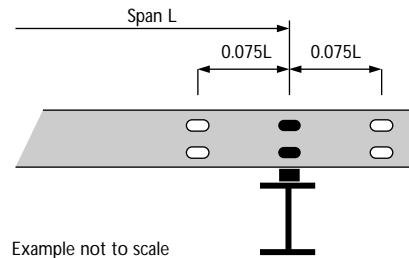

Example not to scale

Structural laps provide greater load carrying capacity to the section. The lap/span ratio must be 15% or greater and all laps should use six bolts, including two through the bottom flange. Z sections can be lapped in any thickness combination and allow heavier, stronger sections to be used in end bay applications.

Laps other than 15% of the purlin span can be manufactured but these must be specified by the design engineer and accounted for in the purlin computations.

Laps for Unequal Spans

As with equal spans, the total lap length must be 15%. However, for unequal spans this means 15% of the average span and the lap is not equally spaced about the support. In practice 7.5% of the longer span must be applied to the shorter purlin (as this material ends up in the longer span). Conversely, 7.5% of the shorter span can be applied to the longer span. This is demonstrated in the example below.

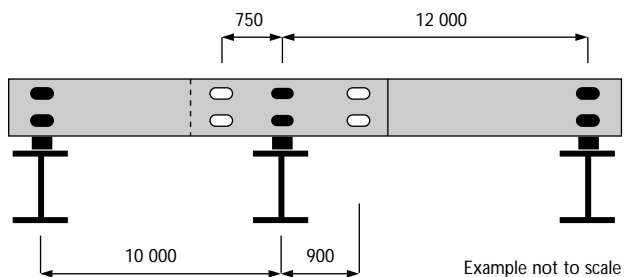

Example not to scale

A satisfactory alternative is simply to apply the 15% lap based on the longer of the spans.

Expansion Joints

The length of roof sheeting is limited by issues associated with thermal expansion and also practical handling limitations. The table below gives recommended maximum sheet lengths.

STRAMIT® PURLINS & GIRTS – MAXIMUM FLAT SHEET LENGTH (m)		
	Through Fixed	Concealed Fastened
Light	25	35
Dark	17	25

The illustration shows a typical expansion joint detail.

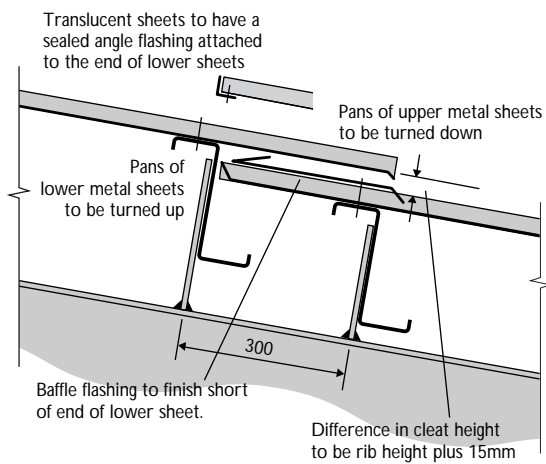

Detailing of Purlins

All purlins are custom cut-to-length and custom punched. It is imperative that precise details are provided to enable the correct product to be supplied. As there are regional variations in the detailing of purlins, each Stramit purlin manufacturing location has developed pro-forma detailing sheets. Contact your nearest Stramit location to obtain a pad of purlin, bridging and accessory detailing sheets.

Key information:

- section size (100, 150, 200, 250, 300, 350)
- section shape (normally C or Z)
- hole centres or gauge (AISC centres for Stramit bridging)
- hole spacings (no closer than 35mm from ends) centre to centre
- hole positions (web, flange or both- for bridging, cleats, laps and fly bracing)
- overall length
- flange orientation / hand (Z flanges must alternate)
- quantity required
- marking number
- delivery address
- delivery date (check with Stramit office)
- bolts, bridging and accessories

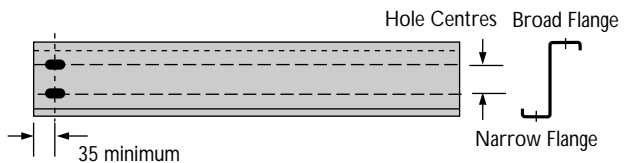

Electronic Detailing

In some Stramit locations, interfaces have been, or are being developed to receive electronic purlin details. This may take form of output from proprietary design packages or from Stramit developed specific purlin detailing software. Talk to your regional Stramit Technical Services Manager about availability and options.

Cleats

Single cleats are used in most situations including for lapped Z purlins. Double cleats are generally only used where successive purlins (usually unlapped) are butted together. Double cleats could also be used in applications with a high reaction load to reduce bolt stresses. In this situation, additional care would be needed in hole detailing.

The table below shows industry standard recommended cleat sizes including purlin clearances.

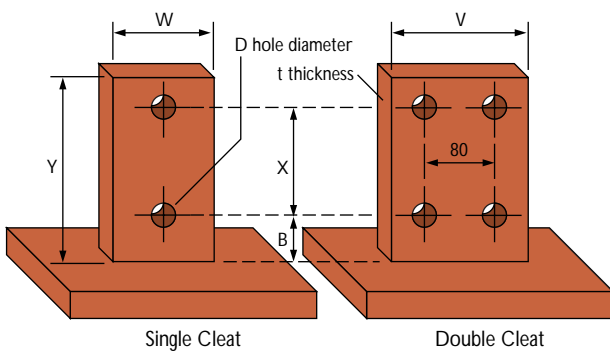

CLEAT NOMINAL DIMENSIONS (mm)								
Section	X	B†	Y†	t	Gap	D	W	V
100	40	40	105	8	10	18	50	130
150	60*	55**	145	8	10	18	60	140
200	110	55	195	8	10	18	60	140
250	160	55	245	8	10	18	60	140
300	210	65	305	12	20	22	60	140
350	260	65	355	12	20	22	60	140

* 70mm in Victoria

** 50mm in Victoria

† When using downturn lip purlins or girts the lip length must be added to dimension B and Y.

Cleat length may need to be increased in some design situations (e.g. above an expansion joint). As a guide, increase the cleat thickness by 2mm for each 40mm of additional length.

Fascia Purlins

There are significant variations in the sections used for Fascia Purlins throughout Australia and for different applications. This variation is reflected in the products offered by Stramit regionally.

The most commonly offered Fascia Purlins are shown below. Contact your nearest Stramit office for availability or refer to the Stramit Price and Service Guide for the area.

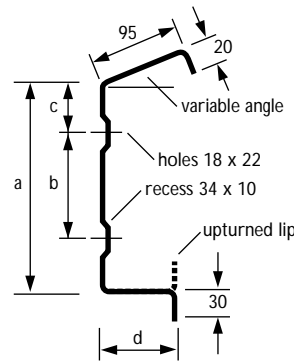

FASCIA PURLIN				
	a	b	c	d
230 Plain	230	110	65	50
230 Fluted	230	110	65	50
260 Plain	260	160	50	60
260 Fluted	260	160	50	60

Fascia Purlins not available at all locations.

It is also common practice to use C section purlins in fascia applications. In some locations these can be supplied with the top flange angled to suit the roof slope.



Nominal heights: 100, 150, 200 and 250.

For dimensions see C section purlins.

Stramit® Purlin Accessories

Stramit® Purlin Accessories are designed for full compatibility with **Stramit® Purlins and Girts**.

Basic Components

See also **Stramit® Bridging** components.



FASTENERS

M12/M16 Integral Flange Bolt & Nut

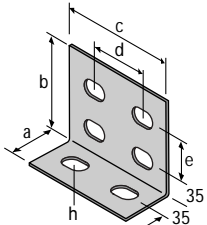

GENERAL PURPOSE BRACKET

	a	b	c	d	e	h
100	60	110	70	40	50	20x17
150	60	125	110	65	65	30x17
200	60	135	160	110	75	30x17
250	65	135	210	160	75	30x17

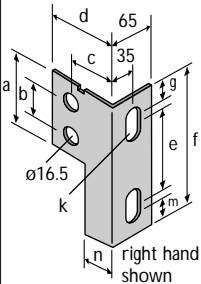

ADAPTOR BRACKET

	a	b	c	d	e	f	g	m	k	n
150-100	68	40	100	125	64	114	12	8	30x16.5	45
200-100	68	40	110	135	110	163	14	9	30x16.5	55
200-150	106	64	110	135	110	158	9	9	30x16.5	55
250-100	68	40	110	135	160	214	15	9	30x16.5	55
250-150	106	64	110	135	160	208	9	9	30x16.5	55
250-200	158	110	110	135	160	208	9	9	30x16.5	55
300-100	68	40	135	160	210	260	30	20	16.5	84

Available left or right handed.

Not available all regions

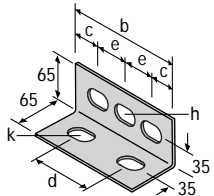

ANGLE CONNECTOR

	b	c	d	e	h	k
100	90	-	-	-	1@60x17	1@60x17
150	140	33	74	37	3@30x17	2@30x17
200	190	40	110	55	3@30x17	2@30x17
250	240	40	160	57	4@30x17	2@30x17

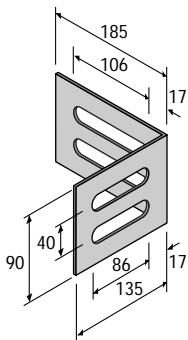

RAKING GIRT BRACKET

100 only

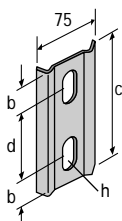

CLAMP PLATE

	b	c	d	e	h
100	25	90	40	-	22x17
150	40	140	60	37	30x17
200	40	190	110	55	30x17
250	40	240	160	57	30x17

Note: Clamp Plates are generally only used in nominal (non-structural) connections.

Bolts

Design Capacities for **Stramit® Purlins and Girts** are based on the use of commercially available bolts. Normally M12 bolts are required for purlins between 100 and 250, whilst M16 bolts are needed for 300 and 350 purlins. Each bolt requires integral washers. The bolt strength grade (4.6 or 8.8) should be specified by the design engineer to conform with the **Stramit® Purlins, Girts & Bridging** – Product Technical Manual.

Hangers/Services

Loads to be suspended from roof purlins must be accounted for in design. No allowance is included in the capacity tables. Any such loadings must be connected to the purlin web by using hangers or other means. Never attach loads to the purlin lips. Attachments to the purlin flange must be within 25mm of the web. Connection design should follow the rules within AS/NZS4600, including a check on bearing of the purlin. Loads should not be suspended from wall girts.

Attach load to or within 25 of web

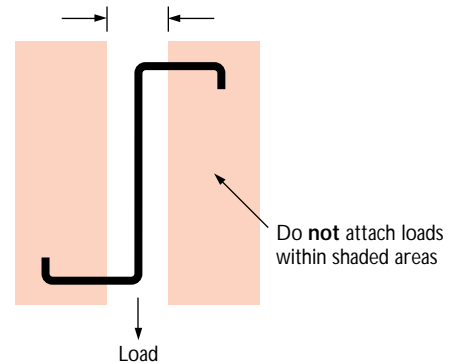

Safety Mesh

In most roof applications safety regulations and good practice will dictate the use of safety mesh on roofs prior to the installation of sheeting or decking.

Guidance on the fixing and laying of safety mesh can be found in Standard Australia Handbook HB39.

Typical Purlin Accessory Assemblies

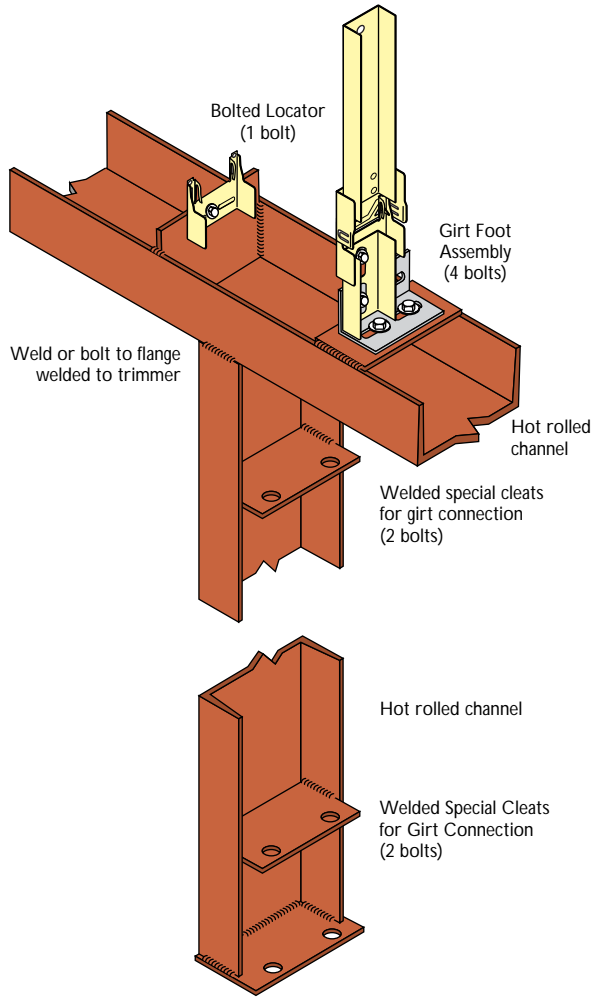

Typical structural door frame using hot rolled channel (by others)

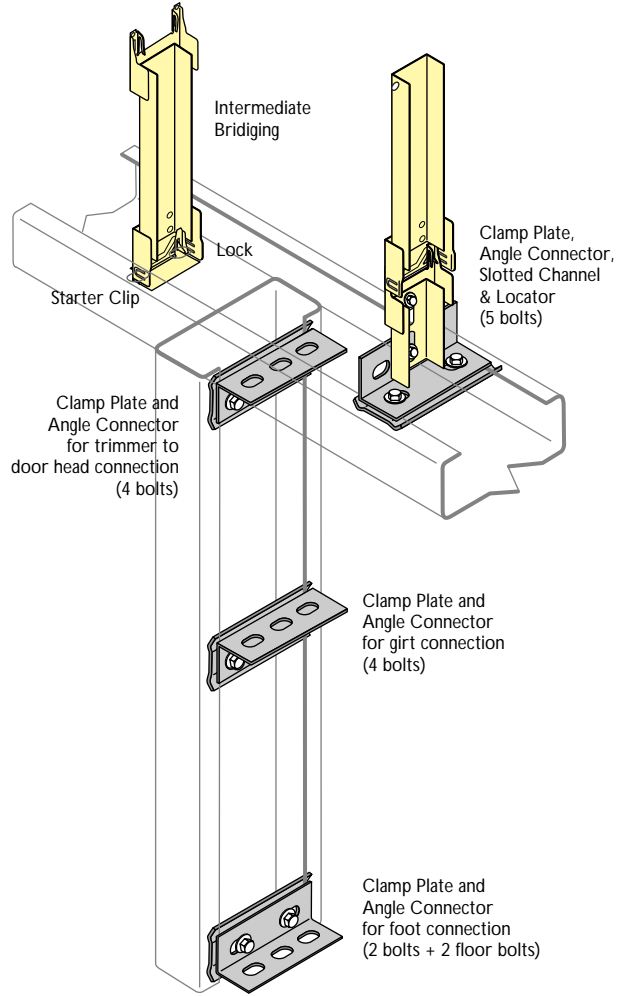

Typical low-duty door frame using C section purlins

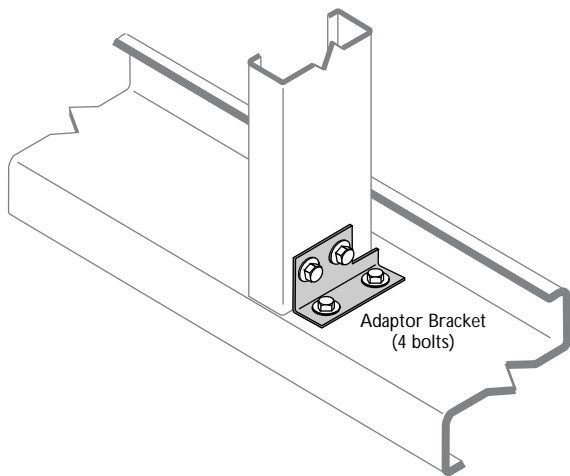

Typical penetration using trimmer of different size to purlin or girt

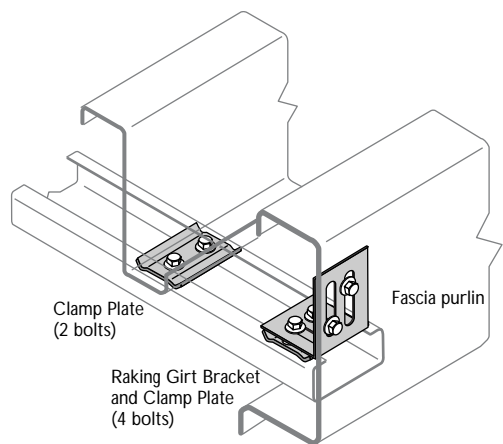

Typical raking girt/ fascia purlin connection

Stramit® Bridging

There are three members of the **Stramit®** Bridging family – **Stramit®** Boltless Bridging, **Stramit®** Bolted Bridging and **Stramit®** Large Series Bridging. All members of the **Stramit®** Bridging family are suitable for use with AISC industry standard hole size and centres.

Applications

Stramit® Boltless Bridging and **Stramit®** Bolted Bridging systems are intended for installation with pre-installed purlin or girts. These systems can only be used with pre-assembled sections to be lifted into place if provision has been made to accommodate the additional forces that may be encountered.

Performance

Stramit® Boltless Bridging and **Stramit®** Bolted Bridging each have a strength limit-state design capacity of 4.0kN in both tension and compression, for bridging lengths up to 2.5m. Maximum wall heights for both systems in girt applications are provided in the **Stramit®** Purlins, Girts & Bridging – Product Technical Manual (Capacity Tables).

Basic Components

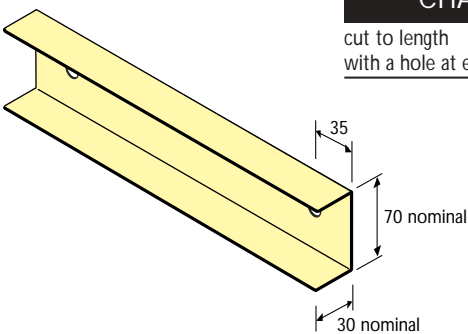

CHANNEL
cut to length
with a hole at each end

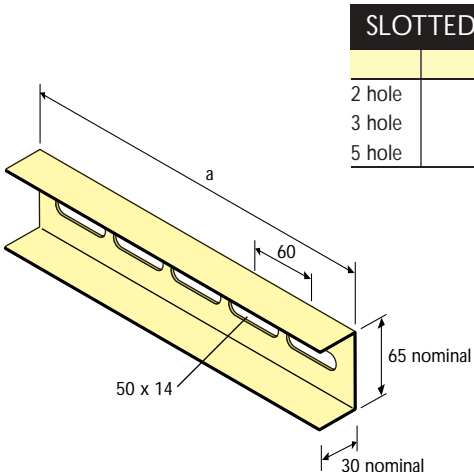

SLOTTED CHANNEL	
	a
2 hole	130
3 hole	190
5 hole	310

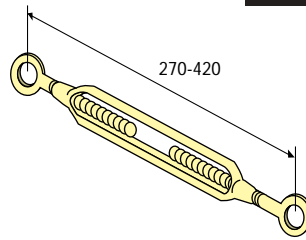

TURNBUCKLE

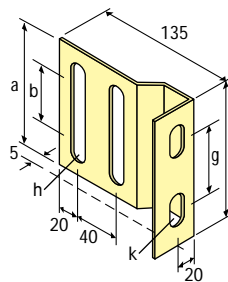

FASCIA BRACKET						
	a	b	f	g	h	k
150	110	-	110	65	2@80x14	2@19x14
200/260	160	80	190	135	4@65x14	2@39x14



FASTENERS	
M12 x 30mm Integral Flange	Grade 4.6 Bolt & Nut
M12 x 30mm Fascia Bolt	Grade 4.6 with Integral Nut
No. 12 x 20mm	Self Drilling & Threading Screws

Stramit® Boltless Bridging

Stramit® Boltless Bridging is a state-of-the-art proprietary system developed for fast installation and optimum compatibility with **Stramit® Purlins and Girts**. Available for purlin sizes between 100 and 250. **Stramit® Boltless Bridging** has been fully tested and engineered for balanced high performance in both compressive and tensile applications. It is interchangeable with **Stramit® Bolted Bridging** by specifying intermediate members with one end Bolted and the other Boltless.

(Note – the terminology ‘Boltless’ refers to the basic lock to locator connection. There are assemblies within the **Stramit® Boltless Bridging** system that require bolts.)

Basic Components

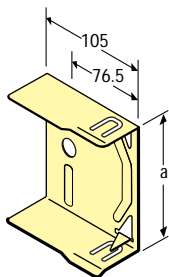

LOCK END	
	a (nominal)
100	60
150	80*
200	130
250	180

*90 in Victoria

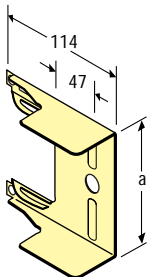

LOCATOR END	
	a (nominal)
100	55
150	75*
200	125
250	175

*85 in Victoria

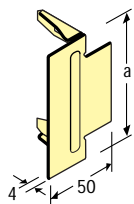

STARTER CLIP	
	a (nominal)
100	63
150	83*
200	133
250	183

*93 in Victoria

Stramit® Boltless Bridging Assemblies

The illustrations on pages 12-17 show typical **Stramit® Boltless Bridging** assemblies and their normal application. Commonly used alternative arrangements are shown.

The suggested arrangement, that assumes installation direction up the roof or wall, is shown. Installation down the roof is also possible, but requires lock and locator component ends to be reversed.

Stramit® Boltless Bridging ends are generally provided with a rigid connection using a set of 4 non-penetrating proprietary (TOX®) connections.

Stramit® Boltless Bridging – typical rigid connection

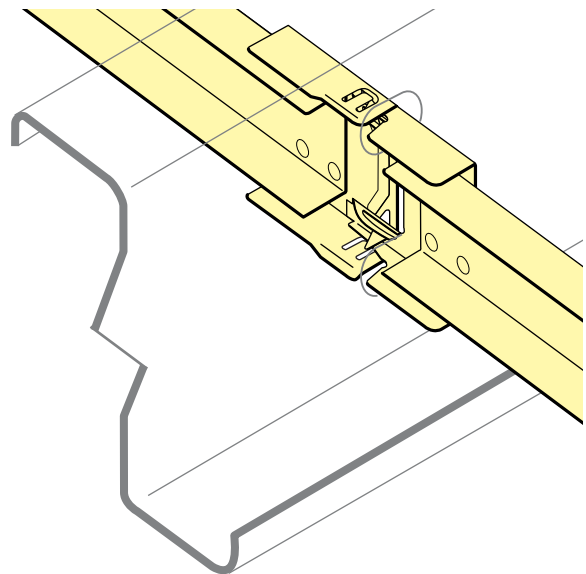

Lock and Locator Ends as well as the plain channel are provided with bolt holes for alternative swivel or out-of-alignment assemblies. It is recommended that such connections be completed by the use of self-drilling screws once the alignment/adjustment is finished.

Stramit® Boltless Bridging – typical swivel connection

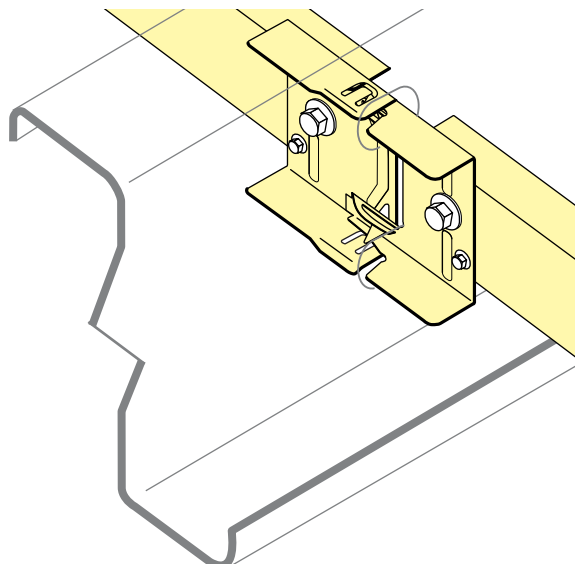

Typical Bridging Assembly Arrangement

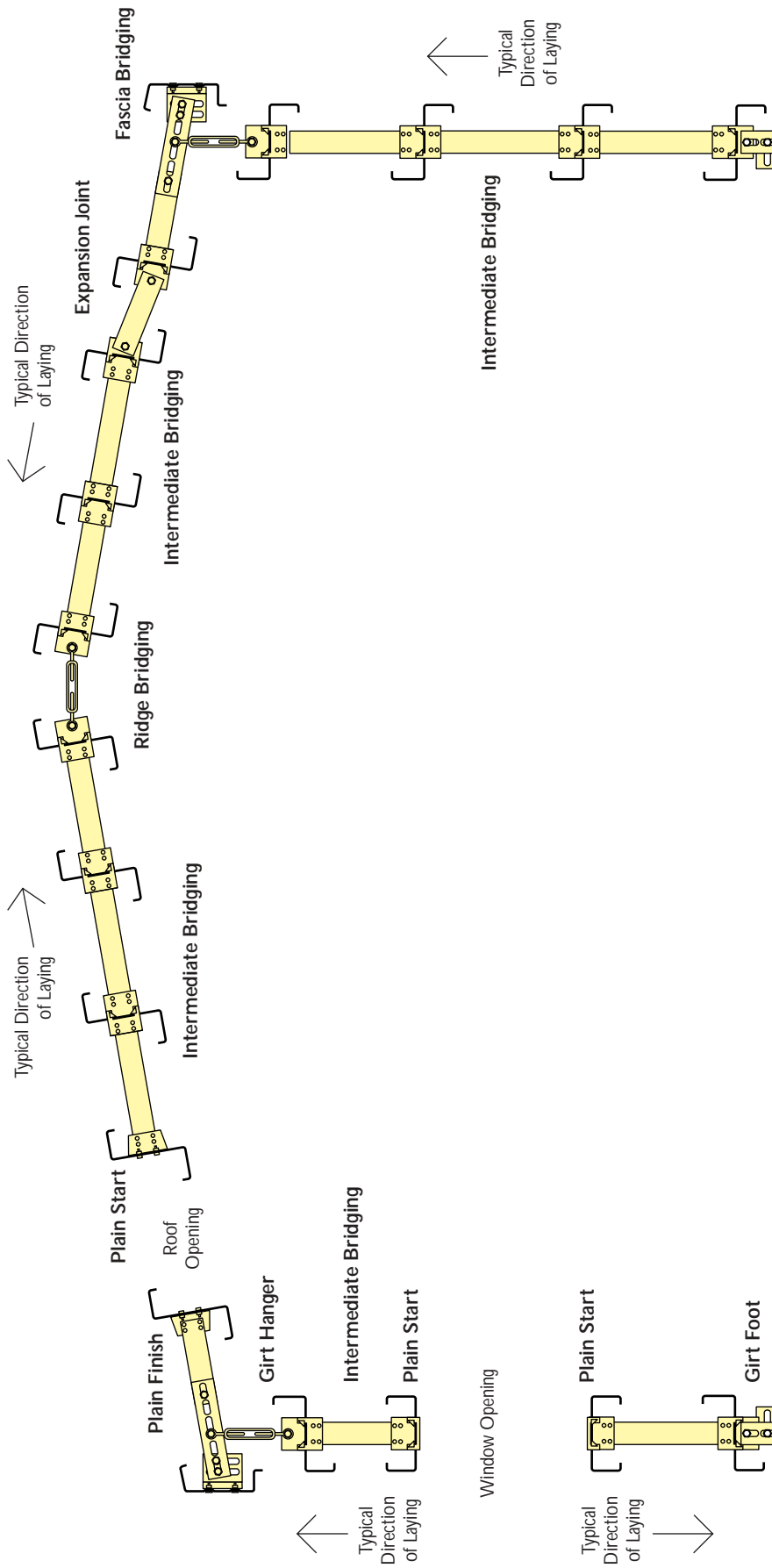

Fascia Bridging

Fascia Bridging is used to provide support to the first internal purlin and for straightening and securing the fascia purlin. Whilst other component combinations are possible, fascia bridging generally comprises of a fascia bracket, slotted channel, plain channel and a locator end.

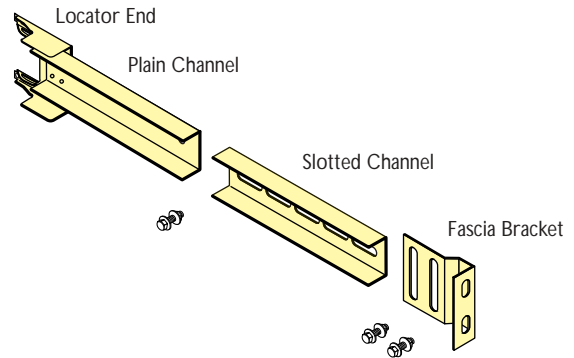
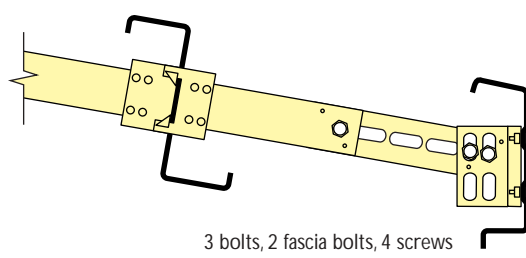

Intermediate Bridging

Intermediate Bridging is the basic connecting member between purlins and generally comprises of a lock and a locator end rigidly connected to a cut-to-length plain channel.

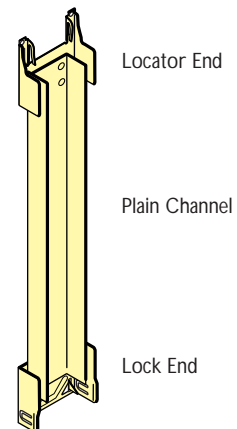
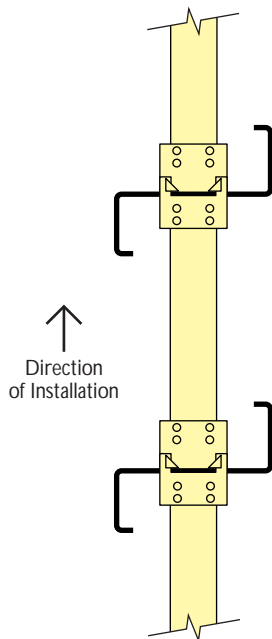
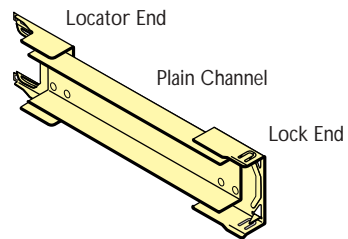
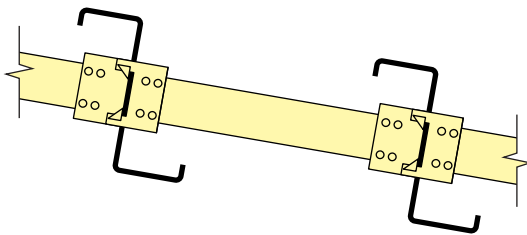

Expansion joint Bridging

typical component combinations are shown below.

Alternative 1

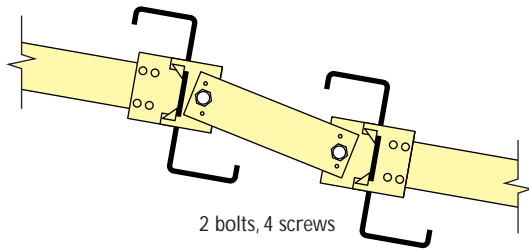

(Available as a rigid [TOX®] connection in Victoria)

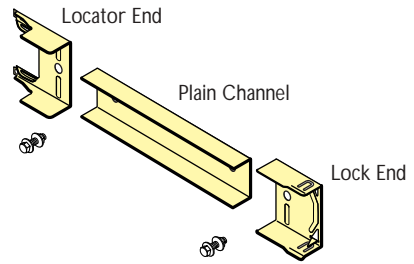

Alternative 2

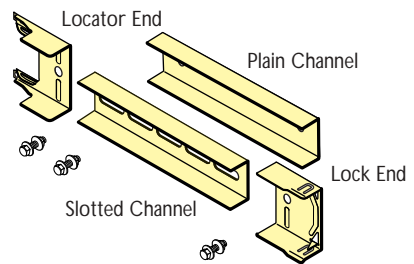
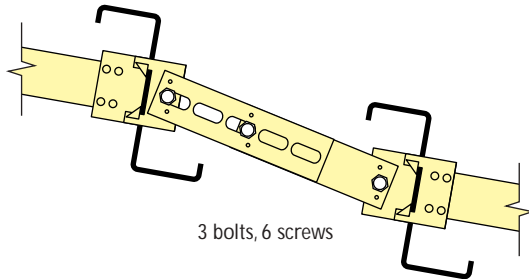

Alternative 3

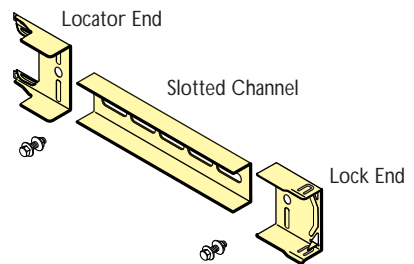
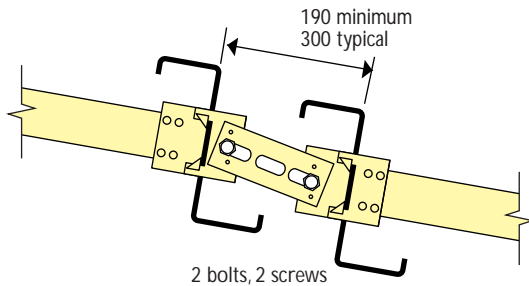

Adjustable Tie Rod Bridging

For light duty applications, Adjustable Tie Rod Bridging may be used to provide alignment and adjustment. This can be used adjacent to Fascia Bridging, Expansion Joint Bridging or Ridge Bridging that comprises of plain channel with a Bolted End. That connection may be a swivel connection secured by screws or a rigid (TOX®) connection. Adjustable Tie Rod Bridging is not suitable for sustaining compressive loads.

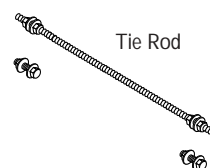
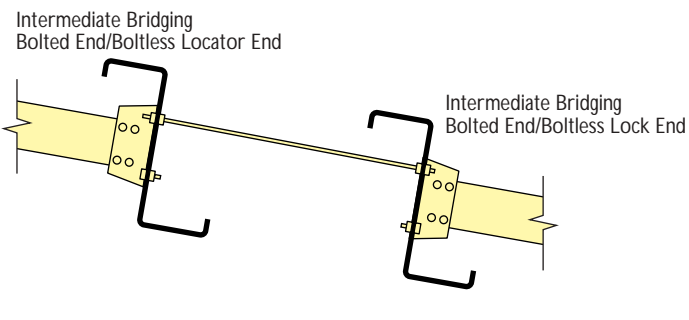

Ridge Bridging

Ridge Bridging is used at the roof apex and is usually adjustable. Several alternatives are available.

Alternative 1

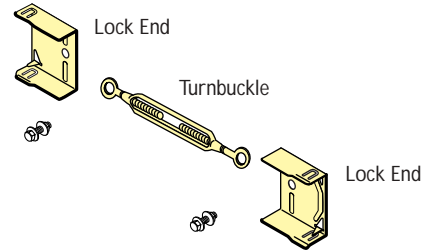
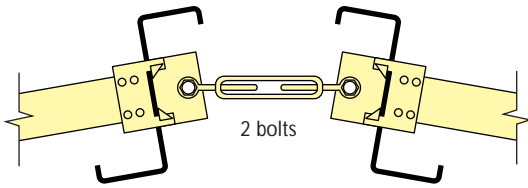

Alternative 2

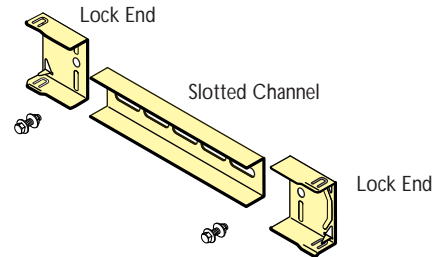
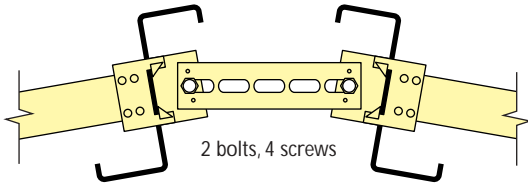

Alternative 3

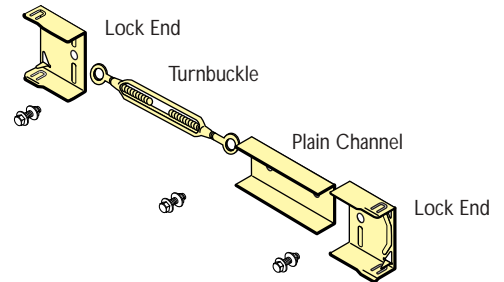
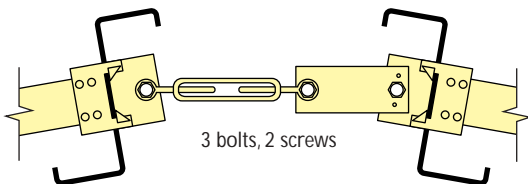

Alternative 4

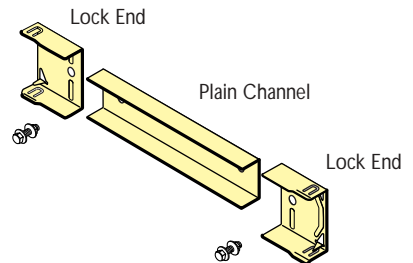
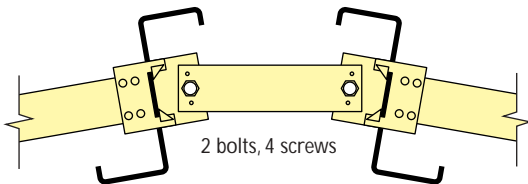

(Available as a rigid [TOX®] connection in Victoria)

Alternative 5

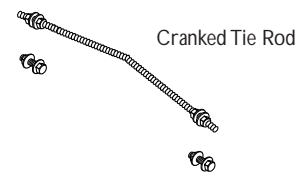
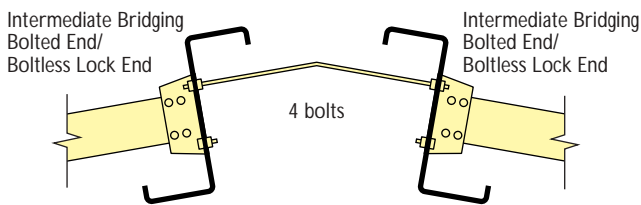

Alternative 6

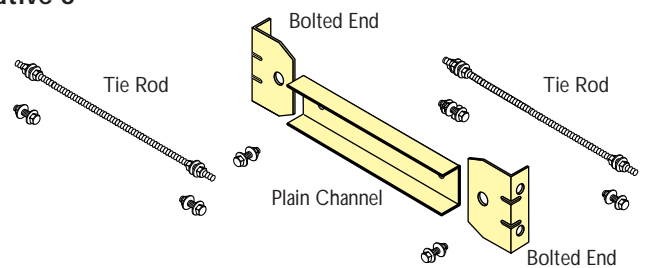
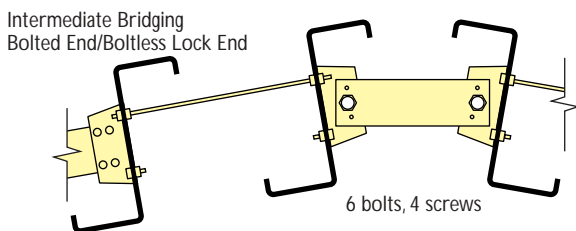

(Available as a rigid [TOX®] connection in Victoria)

Girt Foot

Girt Foot assemblies are used to transfer downward forces in girt bridging to the floor. They also provide some adjustment for alignment of the lowest girt.

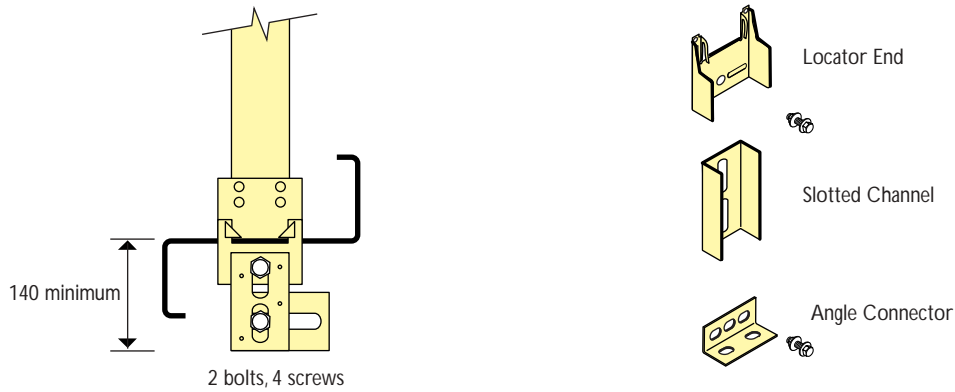

Girt Hanger

Girt Hangers are primarily used to assist in alignment and stabilisation of the fascia purlin. The Girt Hanger is usually attached to the slotted channel in the Fascia Bridging assembly. Girt Hangers should not be used to suspend the wall girts other than for a small number of 100 girts.

Alternative 1

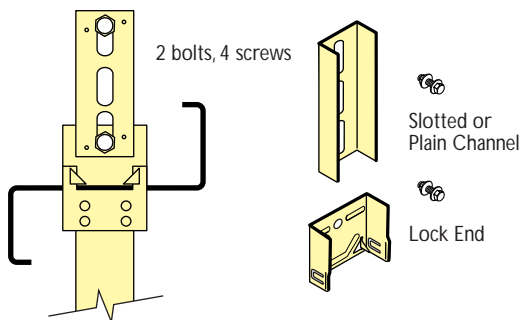

Alternative 2

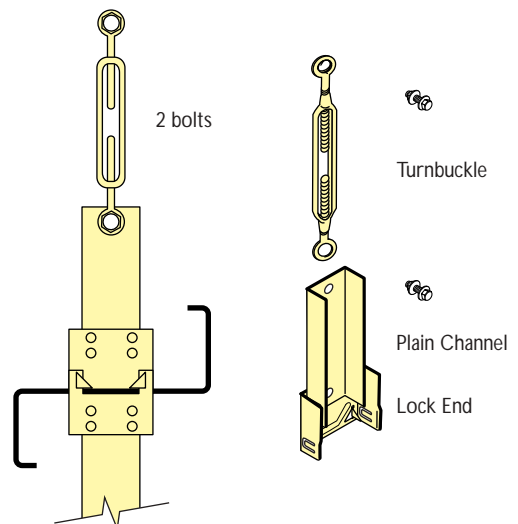

Alternative 3

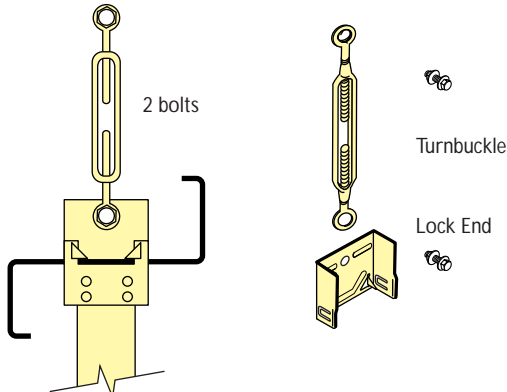

Plain Start

A Plain Start may be required to accommodate a building opening or proximity to an obstruction such as a wall or box gutter. Alternative 3 using a starter clip gives a near flush facing but for heavier duty applications, Alternative 1 using a bolted end may be preferred.

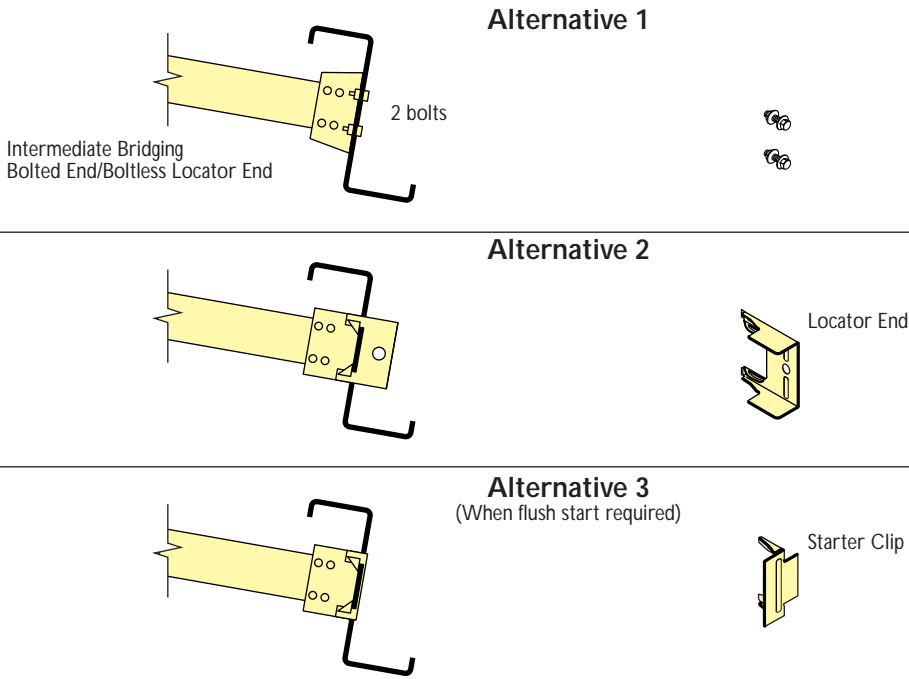

Plain Finish

A Plain Finish may be required to accommodate a building opening or proximity to an obstruction such as a wall or box gutter. Alternative 3 using a starter clip gives a near flush facing but for heavier duty applications, Alternative 1 using a bolted end may be preferred.

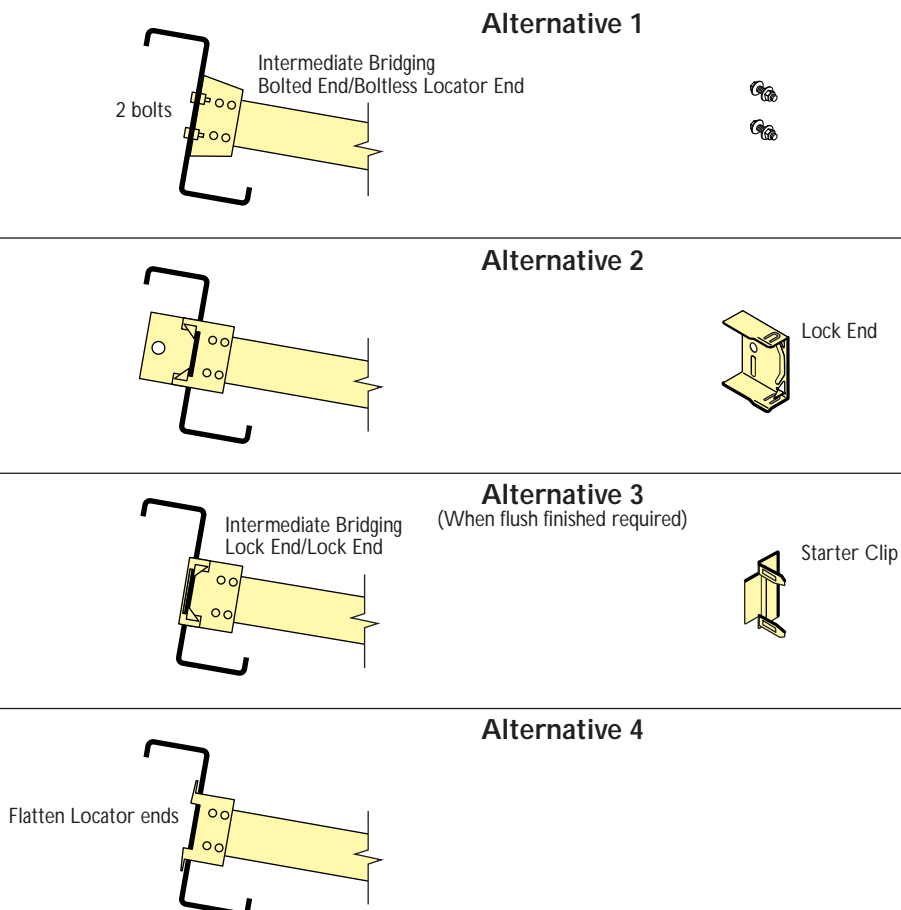

Stramit® Bolted Bridging

Stramit® Bolted Bridging is a conventional bolted system requiring two bolts at each purlin or girt. It is also available for purlin sizes between 100 and 250†. The **Stramit® Bolted Bridging** end bracket and connection has however been carefully designed to give substantially greater performance than simple angle brackets. It is interchangeable with **Stramit® Boltless Bridging** by specifying intermediate members with one end Bolted and the other Boltless.

Assemblies of **Stramit® Bolted Bridging** are similar to those shown for **Stramit® Boltless Bridging**.

† Heavier duty bridging may be required for some 250 purlin applications. This is included in **Stramit® Large Series Bridging**.

Basic Components

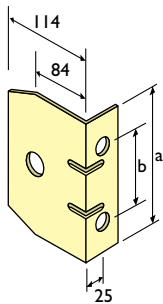
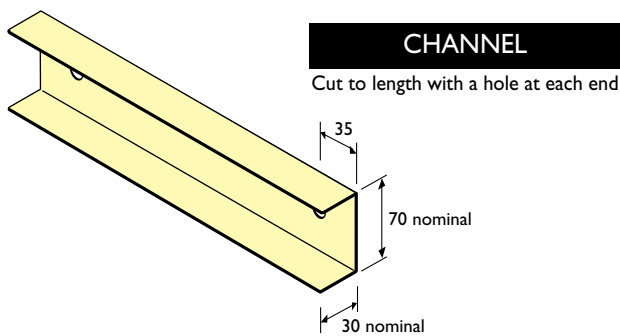

BOLTED END		
	a	b
100	65	40
150	100*	60**
200	150	110
250	200	160

*110 in Victoria

**70 in Victoria



FASTENERS	
M12 x 30mm Integral Flange	
Grade 4.6 Bolt & Nut	

Stramit® Bolted Bridging Ends are generally provided with a rigid connection using a set of 4 non-penetrating (TOX®) connections.

Stramit® Bolted Bridging – typical rigid connection

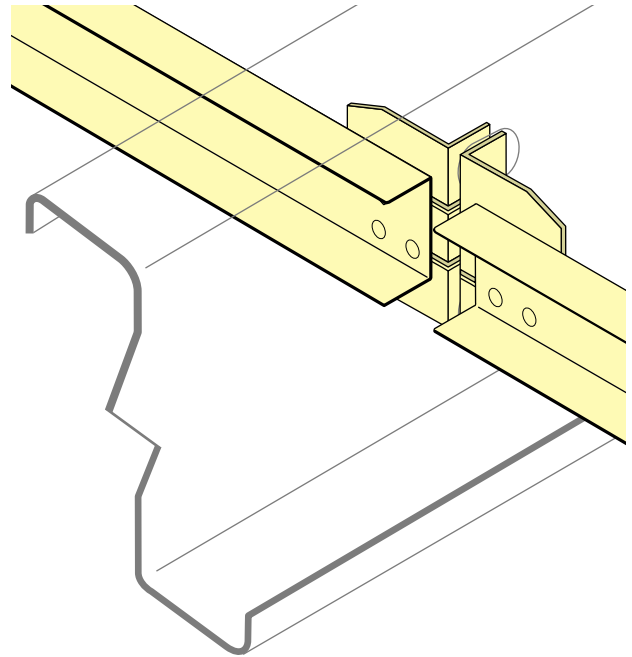

Bolted Ends as well as the plain channel are provided with bolt holes for alternative swivel or out-of-alignment assemblies. It is recommended that such connections be completed by the use of self-drilling screws once the alignment/adjustment is finished.

Stramit® Bolted Bridging – typical swivel connection

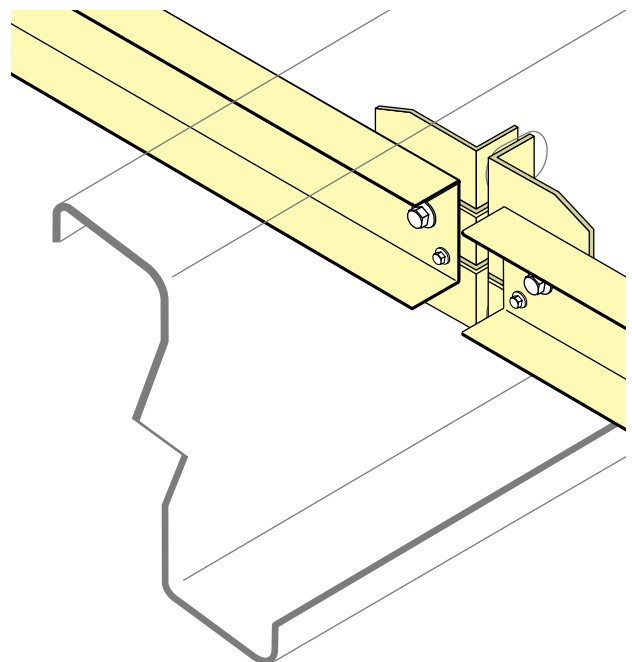

Curved Roofs

Stramit® Boltless Bridging is eminently suitable for curved roofs (that is roofs with parallel purlins supporting sprung curved sheeting). The lock and locator ends of rigid **Stramit® Boltless Bridging** (with TOX® clinched ends - as normally supplied) can accommodate a small amount of angular difference between adjacent purlins. This is reflected in the table below, which shows the minimum radii (the same value as the radii of sprung curved sheeting) that are suitable for this configuration.

MINIMUM CURVED ROOF RADIUS USING RIGID STRAMIT® BOLTLESS BRIDGING (m)

Purlin Size	Purlin Spacing (mm)				
	900	1200	1500	1800	2100
100s	18	24	30	36	42
150s	43	57	72	86	100
200s	63	84	105	126	147
250s	88	117	147	176	205

For radii less than the values in the table above **Stramit® Boltless Bridging** must be ordered in its swivel configuration. In this configuration a bolt connects the lock and locator ends to the bridging channel (note that this configuration can also be used to accommodate purlin out-of-alignment for expansion joints). In this swivel configuration **Stramit® Boltless Bridging** can be used for any practical sheeting radius. (Available as a rigid (TOX®) connection in Victoria.)

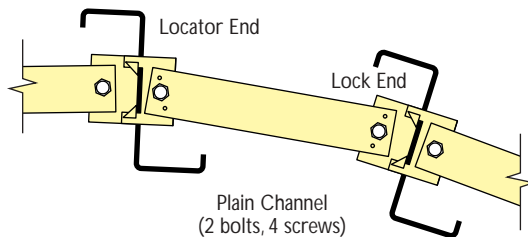

It is recommended that curved roof bridging be locked by using at least two No.12 x 20 hex head self-drilling screws per connection after alignment/adjustment.

Design advice on spring curving radii for **Stramit®** Roof Sheeting and Decking can be found in the Stramit Design Guide - Spring Curving.

Detailing of Bridging

When specifying Bridging lengths, the nominated dimension should be the distance between purlin centre lines.

Example

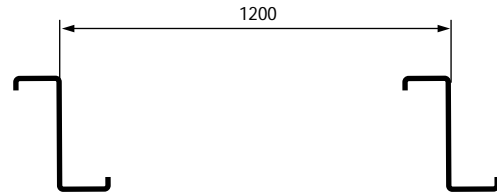

Intermediate Bridging component supplied will be:

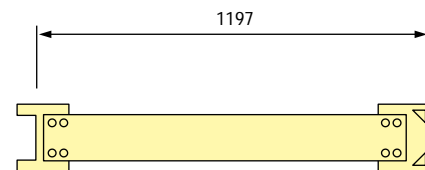

For swivel connected assemblies, the nominated dimensions should be the distance between purlin centre lines and the step height between purlins.

Example

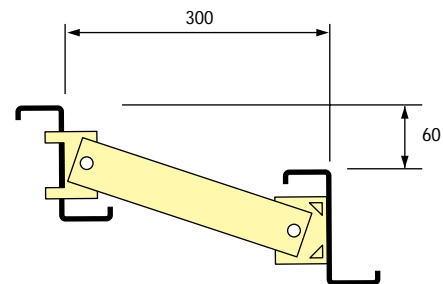

Expansion joint bridging assembly supplied will be:

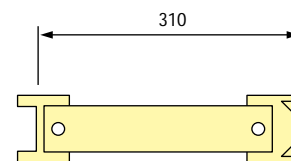

Stramit® Large Series Bridging

Large purlins require large bridging systems due to the larger spans and heavier loads encountered. These bridging components are conventional in nature but on a much larger scale.

Generally the bridging channel is a C150 section firmly bolted to end plates to suit the particular purlin concerned.

Basic Components

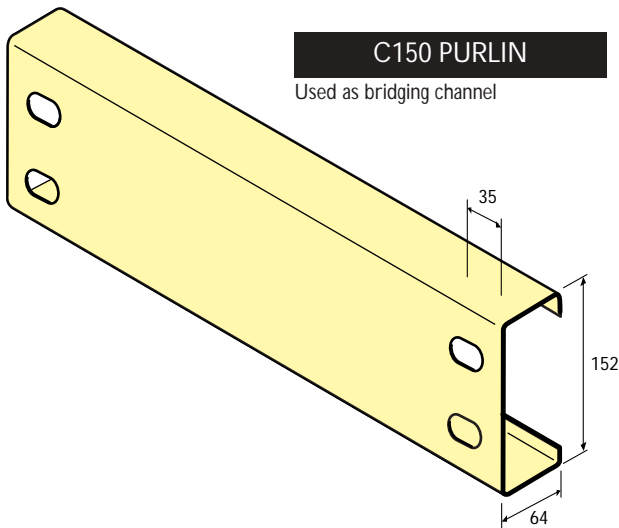

C150 PURLIN
Used as bridging channel

	a	b
250	210	160
300	260	210
350	310	260

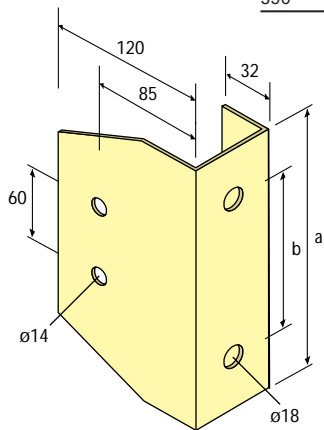

FASTENERS
M12 Integral Flange Bolt & Nut*

* M12 Integral Flange Bolt & Nuts are sufficient for connections between **Stramit® Large Series Bridging** and **Stramit® Purlins**, provided the bridging is installed after the purlins are connected to the in-place building frame. If the bridging is to be used in pre-assembled sections to be lifted into place, the bolt capacities should be separately checked for adequacy.

Stramit® Large Series Bridging – typical connection

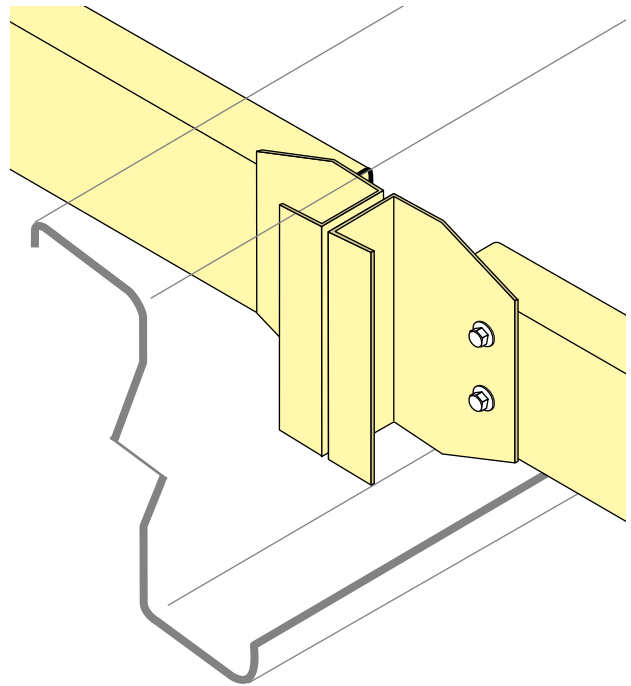

Procurement

Prices

Prices of **Stramit® Purlins and Girts, Stramit® Bridging** and their accessories can be obtained from your nearest Stramit location or distributor of Stramit products.

Lengths

Stramit® Purlins and Girts are supplied cut-to-length. If you are designing or transporting long products ensure that the length is within the limit of the local Transport Authority regulations. All sections are custom-cut to length from 0.6m to 12.6m. For longer lengths, contact your Stramit representative to determine special transport arrangements.

Lengths less than 1.5m may be supplied "sausage" style in a continuous run approximately 5m long with only a small uncut tag connecting the purlin. Simply break off individual purlins on site. Although supplied in a string, each purlin has individual marking labels.

Accessories

Stramit® Bridging for sizes 100 to 250 has a variety of components that are adaptable to all practical applications. Any combination of channel, locator end, lock end and bolted end can be supplied in a pre-assembled form. These are also available in a bolted form for use on curved roofs and at expansion joints.

Stramit® Boltless Bridging is easy to install starting with the locator end and completing with the lock end. A detailed installation leaflet is available upon request.

Stramit® Bridging for sizes 300 and 350 is a heavy duty bolted system which uses a C150 purlin in place of the channel.

Orders

Stramit® Purlins, Girts, Bridging and accessories can be ordered directly from your nearest Stramit location. Exact details of lengths, hole positions and section sizes are required. Ask at your nearest Stramit location for order pad/detailing sheets.

Lead Times

Manufacture of purlins cannot commence without receipt of an order and detail sheets. Please talk to your nearest Stramit branch for current lead times on purlin manufacture and delivery.

Related Products

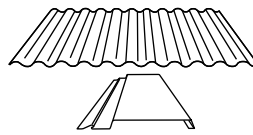

Roof and Wall sheeting
in a comprehensive range to cover all applications.

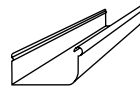

Rainwater goods
in a comprehensive range to cover all applications.

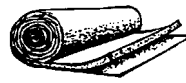

Insulating blanket
in a variety of thicknesses and with or without foil backing.

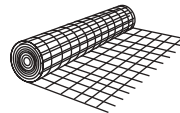

Roofing mesh
for roof safety and blanket support.

Delivery / Unloading

Delivery is subject to delivery location, quantity and material availability, or can be at a pre-arranged date and time. Please ensure that suitable arrangements have been made for truck unloading, as this is the responsibility of the receiver. Pack mass may be up to one tonne.

Installation

Good Practice

Stramit recommends that good trade practice be followed when using these products. Examples can be found in AISC/Australian Standards HB62 part 1 and HB39 and, in some states, health and safety regulations and guidelines.

Inspection

Inspection of purlins and girts should be carried out prior to installation. The ease of inspection, and cost and time lost if remedial action is required, will be substantially less favourable once the purlins have been installed.

Inspection should comprise of checks that labelling is in line with specifications and detailing, and that the section dimensions, hole positions and thickness are exactly to the manufacturer's stated values.

Even small deviations to these values may lead to significant variations in performance from that used in design. It is imperative that this be resolved immediately and prior to installation.

Purlins and Girts supplied by Stramit will be made from high tensile galvanised steel.

Final inspection of the installed purlin, girt and bridging system should check for correct bolting of laps and that bridging is correctly in place. If practical, a check of bolt tightness is highly desirable, both on the purlins and on bolted bridging connections.

Walking

Stramit® Purlins, Girts and Bridging are not designed for walking on. Residual oil may be present on these components from manufacturing. The use of appropriate cradles or cherry pickers is recommended. As a minimum, follow these rules:

- Never walk on purlins without safety mesh in place.
- Always use a safety harness if walking on girts.
- Never walk or place body weight on to bridging.

Bridging

Stramit® Boltless Bridging can be installed either up or down the roof slope. However, as the starting and finishing components will be different, the direction of fixing must be established at the design/procurement phase.

For walls, where more than one row is to be installed, always complete the bridging for each girt before commencing on the next (i.e. Do not complete one row of bridging before starting the next).

Fixing Up the Slope

Fix Fascia Bridging

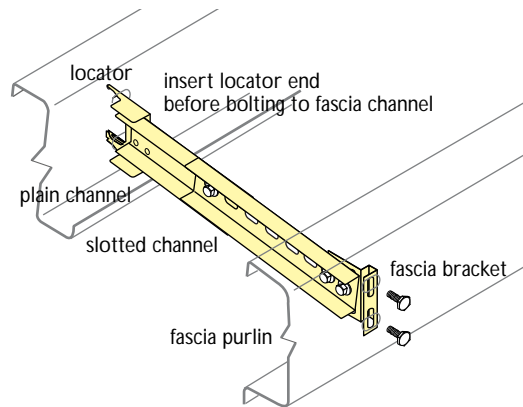

Insert Intermediate Bridging

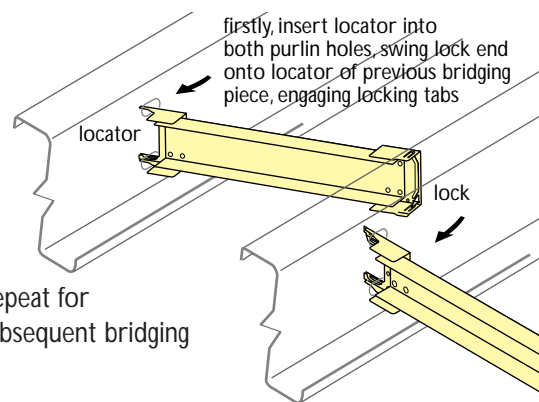

Fix Ridge Bridging.

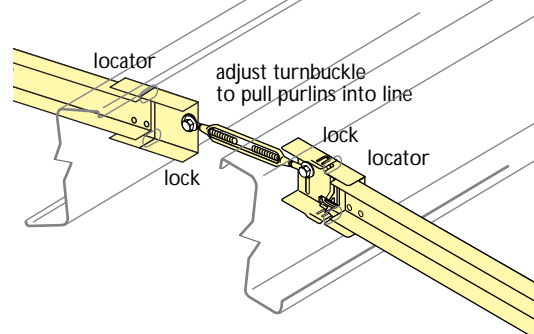

Adjust Fascia Bridging

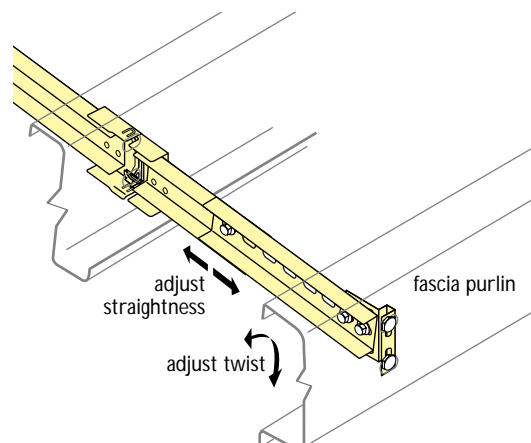

Laps

Purlin laps must be bolted in the top web hole and the lower flange holes at both ends of the lap as shown below. Bolting only in the web of lapped purlins does not provide full structural continuity and excessive loads could be placed on to roofing screws that penetrate both purlins within a lapped region.

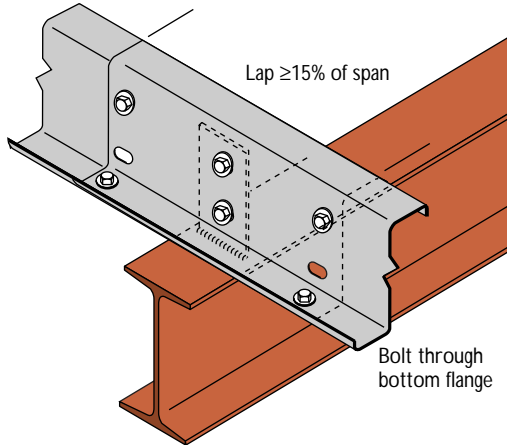

Bolts / Fastening

Always use the correct size and grade of bolts as nominated by the design engineer. Ensure that all bolts are tightened.

It is essential that all bolts are fully tightened prior to roofing installation and before any loads are applied to the purlins, girts or bridging. Swivel assemblies require additional screw fastening prior to roofing and the application of loads.

Fly Bracing

If the lower web hole in a lap is used for attaching fly bracing ensure that an additional bolt is used.

Welding

Stramit does not recommend the welding of purlins, girts or bridging. The heat produced in welding will affect the material properties of the high-tensile cold-formed steel used by Stramit in all its purlins. In many instances considerable stress concentrations are likely to arise, even with good quality welding. In addition welding will locally remove the galvanized coating leading to a potential reduction in durability.

Roofing Mesh

If using insulation blanket, do not overtighten roofing mesh as this may impede the installation of roof sheeting.

Additional Information

Design Service

With the wide variations possible in building design, the publication of specific capacity data becomes increasingly challenging. As a service to its customers, Stramit may be able to assist with more specific purlin capacities to suit particular applications. This includes calculations for:

- special purlin sizes
- downturn lips
- cantilever purlins
- combined different thickness purlins
- different span dimensions
- different lap lengths
- shorter or longer spans than those shown in the tables
- multiple span continuous systems
- design member capacities
- variable UDL within spans
- concentrated loads
- alternative bridging positions
- mixed bridging numbers
- any combination of the above

For more information please contact your regional Stramit Technical Services Manager.

Further Information

As well as our standard range of Technical manuals, Installation Leaflets, Case Studies and other promotional literature Stramit has a series of Guides to aid design.

These include:

- Concealed-Fastened Decking
- Roof Slope Guide
- Foot Traffic Guide
- Roof System Selection Guide
- Bullnosing, Curving and Crimping
- Acoustic Panels
- Cyclonic Areas
- Spring Curving Guide

Please contact your nearest Stramit location for any of these guides, or other literature.

Other Products

Stramit offers a wide range of building products, including:

- Formwork decking
- Roof and wall sheeting
- Lightweight structural sections
- Truss components
- Gutters and downpipes
- Fascias
- Custom flashings
- Insulation products
- Fasteners

References

In preparing this document reference has been made to:

- Standards Australia Handbook - HB39
(Installation code for metal roof and wall cladding)
- AISC/Standards Australia Handbook - HB62.1
(Code of practice for safe erection of building steelwork)
- BlueScope Steel - Technical Bulletin TB-17
(Selection guide for galvanised steel purlin products)



The Stramit web page can be found at:

www.stramit.com.au

Details of many **Stramit**® products can also be seen on the RAI A site 'Product Selector' at:

www.selector.com.au

Building Products

		prices	availability	general	technical
contact numbers for information			products coating colours	other	advice product data
SYDNEY Site A, 33-38 Quarry Road, Erskine Park NSW 2759	phone fax	(02) 9834 0909 (02) 9834 0988		(02) 9834 0900 (02) 9834 0884	(02) 9834 0900 (02) 9834 0977
CANBERRA 4 Bass Street, Queanbeyan NSW 2620	phone fax	(02) 6297 3533 (02) 6297 8089			
COFFS HARBOUR 6 Mansbridge Drive, Coffs Harbour NSW 2450	phone fax	(02) 6652 6333 (02) 6651 3395			
NEWCASTLE 17 Nelson Road, Cardiff NSW 2285	phone fax	(02) 4954 5033 (02) 4954 5856			
ORANGE 51 Leewood Drive, Orange NSW 2800	phone fax	(02) 6361 0444 (02) 6361 9814			
MELBOURNE - KILSYTH 180-186 Colchester Road, Kilsyth VIC 3137	phone fax	(03) 9721 8333		(03) 9721 8333 (03) 9721 8347	
MELBOURNE - BAYSWATER 491 Mountain Highway, Bayswater VIC 3135	phone fax	(03) 9722 5555 (03) 9722 5519	(03) 9722 5500		(03) 9722 5599 (03) 9722 5598
MELBOURNE - PRESTON 219 Dundas Street, Preston VIC 3072	phone fax	(03) 9484 0193 (03) 9484 5060			
MELBOURNE - MULGRAVE 2 Faigh Street, Mulgrave VIC 3170	phone fax	(03) 9484 0193 (03) 9484 5060			
ALBURY 18 Ariel Drive, Albury NSW 2640	phone fax	(02) 6041 7600 (02) 6041 7666			
BENDIGO Ramsay Court, Kangaroo Flat VIC 3555	phone fax	(03) 5447 8455 (03) 5447 9677			
HOBART 57 Crooked Billett Drive, Brighton TAS 7030	phone fax	(03) 6263 5536 (03) 6263 6950			
LAUNCESTON 9 Richard Street, Western Junction TAS 7212	phone fax	(03) 6391 9293 (03) 6391 8774			
ADELAIDE 11 Stock Road, Cavan SA 5094	phone fax	(08) 8262 4444 (08) 8262 6333		(08) 8262 4444 (08) 8262 6333	
BRISBANE 57-71 Platinum Street, Crestmead QLD 4132	phone fax	(07) 3803 9999 (07) 3803 1499		(07) 3803 9999 (07) 3803 1499	
TOWNSVILLE 402-408 Bayswater Road, Garbutt QLD 4814	phone fax	(07) 4779 0844 (07) 4775 7155			
CAIRNS Vickers Street, Edmonton QLD 4869	phone fax	(07) 4045 3069 (07) 4045 4762			
MACKAY Brickworks Court, Glenella QLD 4740	phone fax	(07) 4942 3488 (07) 4942 2343			
MARYBOROUGH 10 Activity St, Maryborough QLD 4650	phone fax	(07) 4121 2433 (07) 4123 3139			
GLADSTONE 25 Beckinsale St, Gladstone QLD 4680	phone fax	(07) 4972 8455 (07) 4972 8355			
ROCKHAMPTON 174-176 Alexandra St, Nth Rockhampton QLD 4701	phone fax	(07) 4927 3855 (07) 4922 2857			
SUNSHINE COAST 9 Textile Avenue, Warana QLD 4575	phone fax	(07) 5493 7035 (07) 5437 8148			
MURWILLUMBAH 6 Kay Street, Murwillumbah NSW 2484	phone fax	(02) 6672 8542 (02) 6672 6798			
DARWIN 55 Albatross Street, Winnellie NT 0820	phone fax	(08) 8947 0780 (08) 8947 1577			
PERTH 605-615 Bickley Road, Maddington WA 6109	phone fax	(08) 9493 8800 (08) 9493 8899			
BUNBURY 25 Proffit Street, Bunbury WA 6230	phone fax	(08) 9721 8046 (08) 9721 8017			

® Registered trademarks of Stramit Corporation Pty Limited. ABN 57 005 010 195 trading as Stramit Building Products

A member of the Fletcher Building Group

TOX® is a registered trade mark of Tox Pressotechnik GmbH.

© Stramit Corporation Pty. Limited October 2005.

This document replaces all previous issues. Please destroy, or clearly mark as superseded, all previous issues.